



# MATRIX Prometheus

Thermal Energy Harvesting Module

## Features & Benefits

### Highest performance

- Starts up from a temperature difference as low as 0.5°C
- Operating temperature range of -40°C to +85°C, satisfying common industrial and commercial operating requirements

### Highly integrated thermal energy harvesting modules

- Combines high performance TEG with world's most efficient energy harvesting boost converter
- Perfect electrical impedance matching

### Easy to use

- Select the appropriate thermal impedance for application
- Add heat sink and mount to heat source

### Applications



Wearables



Industrial Process Monitoring



Waste Heat Harvesting

## Product Brief

MATRIX Prometheus is a family of energy harvesting modules designed for converting thermal energy between small temperature gradients into useful electrical output.

Each Prometheus module integrates a MATRIX Gemini Thermoelectric Generator (TEG) with a MATRIX Mercury Energy Harvesting Boost Converter. This patented technology ensures perfect electrical impedance matching between the TEG and its companion Boost Converter. Such integration enables MATRIX Prometheus to produce much greater output current than equivalent competitive solutions under identical conditions.

Multiple thermal impedance options between 2K/W and 37K/W may be selected, with matched heat sinks available for each of these options. Several maximum output voltages ( $V_{OUT}$ ) between 2V and 5V are available, allowing the module to directly power integrated circuits, or charge various battery chemistries without needing additional charger circuitry. Integrated  $V_{OUT}$  regulation prevents voltage overshoot, securing reliable operation with various battery types.

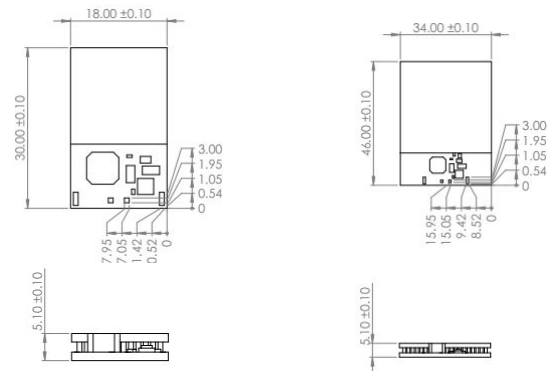

MATRIX Prometheus dimensions for standard options. Custom shapes and sizes available upon request.

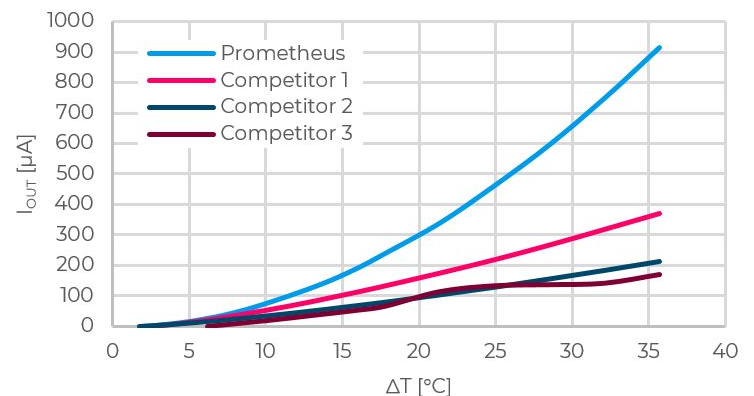

Output current  $I_{out}$  vs temperature difference  $\Delta T$  between hot side and ambient for Prometheus and equivalent solutions with thermal impedance of 21K/W. Assuming ideally matched heat sinks, ambient temperature of 23°C, and output voltage of 4.2V.

## MORE INFORMATION